

DESIGN

INSTALLATION

MAINTENANCE

COMBUSTEX

BURNER IGNITION & CONTROL SYSTEMS

PRODUCT MANUAL



The Combustex Series 100 *C/I Standard Safety Shutoff Valve*

Phone: (403) 342-4494 | Email: sales@combustex.com | Web: www.combustex.com

Call Us Toll Free: 1-855-226-2582

CANALTA
CONTROLS GROUP

Standards & Certifications

ANSI Z21.20 - 2005
CSA 6.5 - 2005
ANSI / ISA 12.12.01 - 2007
CSA 22.2 No. 213 - M1987
Class 1, Div. 2 Groups B, C and D Haz. Loc.
Temp. Code T6
NEMA Type 4



..... CONTENTS

Warnings	p 1
Design Overview	p 2
Standard Valve Assembly	p 3
Standard Valve Specifications	p 4
Installation	p 5
Gas Line Piping	p 5
Actuator Piping	p 6
Maintenance	p 7

..... **WARNINGS**



Combustex recommends that this manual be read thoroughly *before* attempting installation or use of the Series 100 valves. **SAFETY FIRST.**



To avoid personal injury, death or equipment damage, all instructions relating to installation and maintenance must be strictly adhered to. Installation and maintenance is to be carried out only by qualified personnel.



-- WARNING --

THIS EQUIPMENT IS SUITABLE FOR USE IN CLASS 1, DIVISION 2 GROUPS B, C, D OR NON-HAZARDOUS LOCATIONS ONLY.

-- WARNING --

EXPLOSION HAZARD - DO NOT DISCONNECT EQUIPMENT WHILE CIRCUIT IS LIVE UNLESS AREA IS KNOWN TO BE NON-HAZARDOUS

-- WARNING --

EXPLOSION HAZARD - SUBSTITUTION OF COMPONENTS MAY IMPAIR SUITABILITY FOR CLASS 1, DIVISION 2 LOCATIONS.

-- AVERTISSEMENT --

RISQUE D'EXPLOSION - LA SUBSTITUTION DE COMPOSANTS PEUT RENDRE CE MATERIEL INACCEPTABLE POUR LES EMPLACEMENTS DE CLASSE 1, DIVISION 2.



DESIGN OVERVIEW

The Combustex Series 100 C/I Standard Safety Shutoff Valve is designed for safety and efficiency, offering throttling or on / off control of low pressure liquid and gas flow. This “fail-closed” valve was specifically developed to be a C/I Safety Shutoff Valve in compliance with CSA B149.3-10, CSA 6.5-05 and ANSI 21.21-05, meeting or exceeding the requirements for safe operation of fired heaters.

With tapped vent ports, sealed spring case and HNBR sealing components, the Combustex Series 100 Standard Safety Shutoff Valve is designed to be used with either air or natural gas as the diaphragm operating medium.

This valve is capable of effective operation in a wide variety of applications and industries where on / off or proportional control with a positive seat seal are required.

Key features include:

- Balanced plug design with soft seat
- Corrosive fluid compatibility
- H₂S gas service compliance (with optional materials)
- Ease of maintenance
- Ease of Installation
- Leak protection
- Natural gas actuated capability
- Visual indication of valve position

The Combustex Series 100 C/I Standard Safety Shutoff Valve has been rated for a maximum working pressure of 60 psi. This is the maximum pressure rating for automatic valves under CSA 6.5 / ANSI Z21.21 and is more than sufficient for most applications. In the course of certification, the valve seat was successfully tested to 90 psi, and all other valve parts to 300 psi.

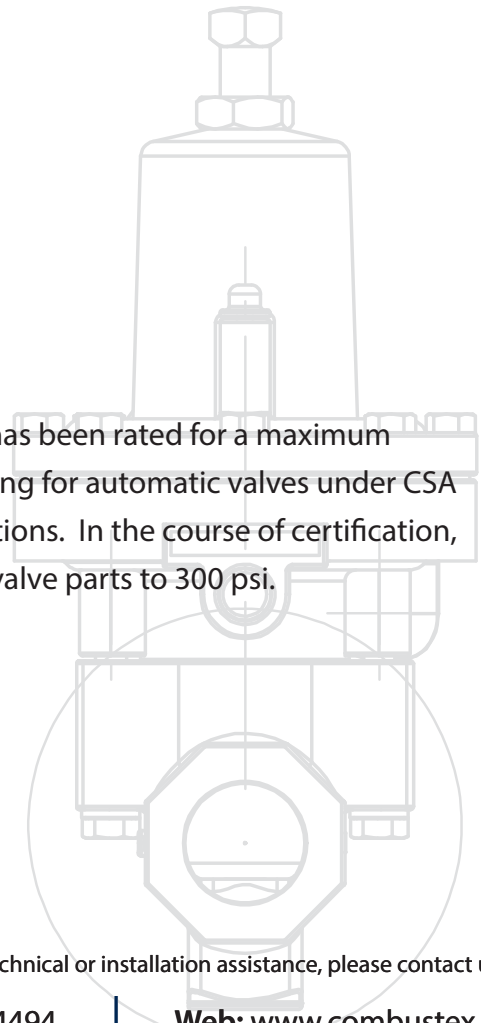

For operational, technical or installation assistance, please contact us.

Phone: 403.342.4494

Web: www.combustex.com

Call Us Toll Free: 1-855-226-2582

Combustex Series 100

C/I STANDARD SAFETY SHUTOFF VALVE

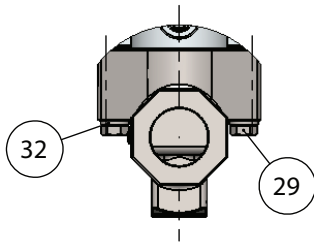

END VIEW

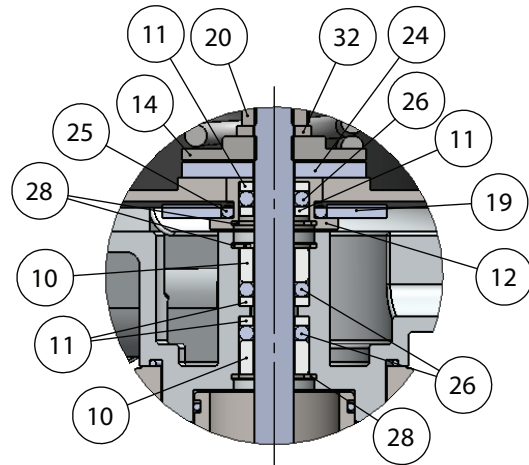

DETAIL B

Item	Qty.	Description	Part No.
1	1	Valve Body	100-001-1
2	1	Bonnet	100-002-1
3	1	Spring Case (Standard Model)	100-003-1
4	1	Cage	100-005-1
5	1	Valve Plug	100-006-1
6	1	Valve Stem	100-013-2
7	1	Diaphragm	100-014-1
8	1	Valve Spring - 3-15 PSI (Standard Model)	100-015-1
9	1	Valve Spring - 6-30 PSI (Standard Model)	100-015-2
10	2	Stem Seal Bushing	100-018-1
11	4	Stem Seal Retainer Ring	100-019-1
12	1	Diaphragm Guide	100-022-2
13	1	Diaphragm Spring Plate	100-025-2
14	1	Shaft Spring Plate	100-026-1
15	1	Position Indicator Shaft (Standard Model)	100-029-1
16	1	Indicator Shaft Spring	100-030-1
17	1	Indicator Cap	100-031-1
18	1	Spring Adjustment Plate	100-039-1
19	1	Diaphragm Washer	100-024-2
20	1	Shaft Lock Nut	NHJF-0313-CS
21	3	Inner & Lower Cage Seal #020	O020-80H
22	1	Upper Cage Seal #024	O024-80H
23	1	Valve Seat Seal #114	O114-90H
24	1	Diaphragm Guide Spacer	100-045-1
25	1	Diaphragm Guide Outer Seal #114	O114-80H
26	3	Stem Packing Seal #203	O20380H
27	1	Body Seal #030	O030-80H
28	4	Packing Snap Ring	SRI-0625
29	2	Body Bolt	BHC-0313-2250-B7M
37	1	Spring Adjustment Jam Nut	NHJF-0500-CS
31	1	Spring Adjustment Set Screw	BSQOF-0500-2000-CS
32	3	Lock Washer	WL-0313-CS
33	1	Plug Retainer Pin	PG-0094-0500-316
34	8	Spring Case Bolt	BHC-0250-1000-CS
35	1	Specification Tag	100-042-1
36	4	Specification Tag Drive Screw	PD-0125-0125-CS

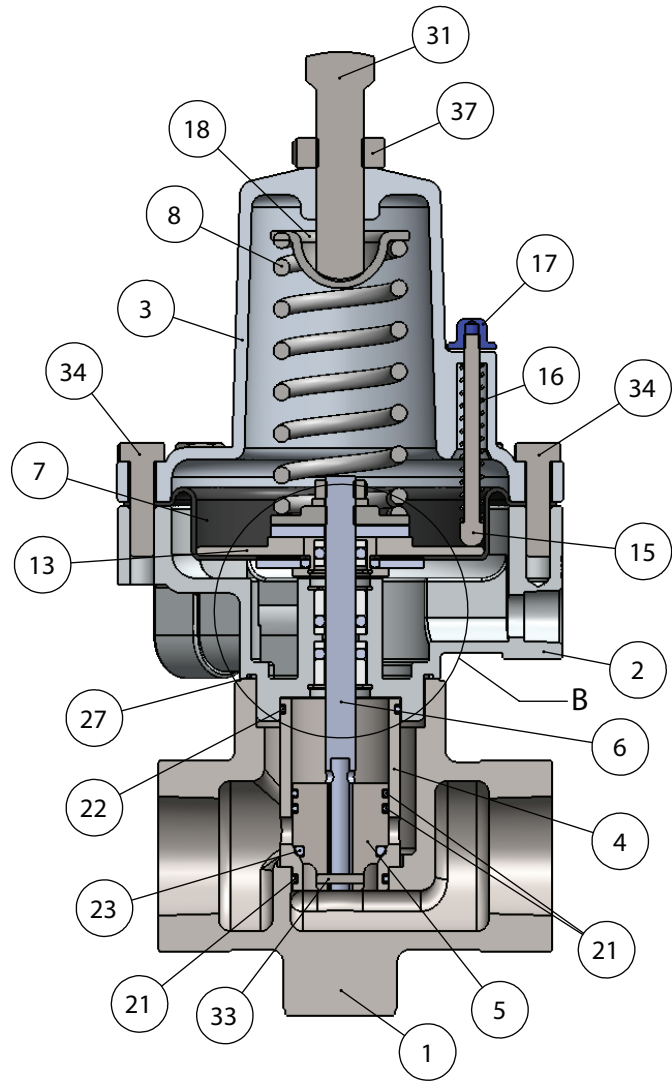

SECTION A-A

For operational, technical or installation assistance, please contact us.

Phone: 403.342.4494

Web: www.combustex.com

Call Us Toll Free: 1-855-226-2582

Technical Specifications - C/I STANDARD SAFETY SHUTOFF VALVE

Operational

BTU Rating	15,968,000 BTU/Hr. (@ 60 Psi supply with 10% P.D.)
Cv Rating	8.1
Fail Postition	Closed
Max. Working Pressure	60 PSIG (377 kPa)
Ambient Temp. Range	-40°C to +40°C (-40°F to +104°F)
Body Connection Size	1" Female NPT - Inlet & Outlet
Supply / Vent Connection Size	1/4" Female NPT
Valve Plug Style	Tapered Balanced Plug
Valve Seat Diameter	3/4" (19.05mm)
Valve Plug Travel	3/4" (19.05mm)
Maximum Pressure Drop	60 PSIG (377 kPa)
Actuator Spring Range	Standard: 3 to 15 PSIG (18.9 to 94.4 kPa) Optional: 6 to 30 PSIG (37.7 to 189 kPa)
Max. Spring Case Pressure	50 PSIG (315 kPa)

Materials

Body	A216 WCB, A352 LCC Steels
Bonnet	Aluminum (A216 WCB optional)
Spring Case	Aluminum
Valve Plug, Cage & Stem	316 Stainless Steel
Soft Seat	HNBR Standard (other materials optional)
Packing	Teflon and HNBR Standard
Diaphragm & Assoc. Seals	HNBR
Body Bolting	Standard: Clear Zinc Plated Steel Optional: B7M Bolting
Spring Case Bolting	Clear Zinc Plated Steel
Springs	Clear Zinc Plated Steel
Unit Weight	~ 6 lbs. (2.73 Kg.)

INSTALLATION



To avoid personal injury, death or equipment damage, all instructions relating to installation and maintenance must be strictly adhered to. Installation and maintenance is to be carried out only by qualified personnel.

The Series 100 C/I Standard Safety Shutoff Valve has a fail closed design. The valve is to be installed with safety limit interlocks that are wired or piped in series to the supply of the actuator. The safety interlocks are to block and bleed the signal when the safety limit is reached or exceeded. Ensure that no manual overrides or bypasses exist on the safety interlock components. With a balanced valve plug, the valve is capable of tight shutoff over the complete maximum working pressure range of the valve. The Standard Valve is capable of - and intended for - either on/off or throttled control of the feed gas to the main burner of a commercial or industrial gas burning appliance.

Gas Line Piping Installation

The valve is to be installed in compliance with all local gas authority regulations and, in jurisdictions within Canada, in accordance with CSA B149.3 piping requirements. The unit is approved for use with natural gas or propane. Ensure that the flow direction marked on the body corresponds with the flow of gas to the burner. Fuel gas line pressure is not to exceed 60 PSIG (377 kPa) and installation of a relief valve upstream of the Safety Shutoff Valve with a setting not exceeding 60 PSIG is required. An approved thread lubricant or sealant must be used on the inlet and outlet threaded pipe gas connections. The Combustex Series 100 C/I Standard Safety Shutoff Valve is to be installed with the spring case in the vertical position above the body.

Actuator Piping Installation

Supply medium to the actuator may be either clean dry compressed air or natural gas. Maximum pressure to the actuator section is 50 PSI (315 kPa) but the unit is designed for proportional control by either a 3 - 15 PSI signal as standard or a 6 - 30 PSI signal as optional. All supply and vent connections are tapped ¼" FNPT.

Piping of the actuator supply shall be a minimum ¼" tubing or pipe. Pipe the vent connections to a safe venting location. Do not pipe vent connections into a relief valve discharge system. Vent lines shall be a minimum ⅜" tubing or ¼" piping. Ensure fluid traps do not exist in the vent lines and that the vent lines are kept as short and free of bends as possible. In the case of a solenoid feed to the supply side of the actuator, ensure that the piping size of the solenoid is a minimum ⅛" NPT and that the porting in the solenoid is a minimum ⅛" diameter on both the supply and the exhaust sides. Do not install manual valves in the supply feed to the actuator downstream of any safety interlock devices.

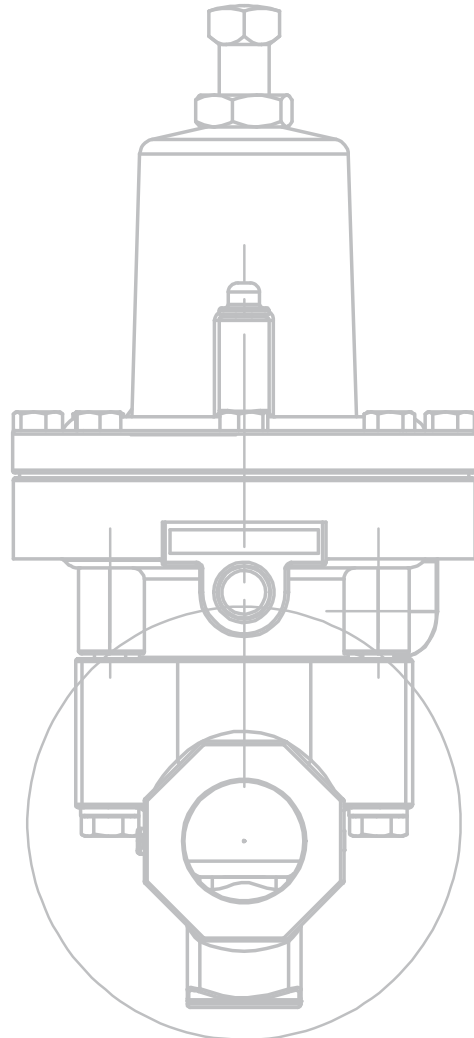

For operational, technical or installation assistance, please contact us.

Phone: 403.342.4494

Web: www.combustex.com

Call Us Toll Free: 1-855-226-2582

MAINTENANCE

The valve is designed for ease of maintenance on the valve sealing components. Removal of two body bolts allows full access to the valve plug, cage and body seals. Under normal operating conditions, valve sealing components should be inspected yearly. Replace components as needed.



Prior to attempting maintenance, refer to the applicable Series 100 C/I Standard Safety Shutoff Valve assembly drawings (p. 3).

REPLACING VALVE SEAT SEALING COMPONENTS

1. Ensure that all gas pressure has been shut off and that the flow line is bled down of any gas pressure. Lock out the upstream manual block valve if it is not within view.
2. Loosen the jam nut (#37). Mark the position of the spring adjustment screw (#31) and rotate counter clockwise to remove all spring action.
3. Remove the two body bolts (#29).
4. Separate the lower body (#1) from the top section of the valve.
5. Pull the valve cage (#4) from the lower body.
6. Inspect the valve plug (#5) and cage for wear. Should any wear be apparent, replace the worn components.
7. Remove the lower cage seal (#21), upper cage seal (#22), inner cage seals (#21), valve seat seal (#23) and body seal (#27).
8. Replace all seals mentioned in step 7 with new seals of the same composition and durometer as stated in the parts list (see p. 3). Ensure that a high quality, approved O-ring lubricant is applied to all seals prior to installing.
9. Apply a film of O-ring lubricant to the inside of the valve cage (#4).
10. Insert the valve cage into the lower body, ensuring that the lower cage seal (#21) snaps into the O-ring cavity of the lower body.

(Cont'd on next page)

11. Reinstall the upper valve section to the lower body (#1), ensuring that the valve plug (#5) slides freely into the valve cage.
12. Reinstall the body bolts (#29) by hand tightening, ensuring that the lock washers (#32) are in place and that the upper section of the valve is sitting squarely on the lower body.
13. Evenly torque down the body bolts (#29) by alternating from side to side.
14. Reapply spring tension to the upper section by rotating the spring adjustment screw (#31) clockwise to the point marked earlier. Tighten the jam nut (#37).
15. Slowly open the manual upstream block valve. With a snoop leak soap mixture, test the body seal for leaks.
16. Ensure that the valve plug seal is holding by closing the downstream manual block valve and by checking for pressure build-up on a gauge between the outlet of the valve and the downstream block valve.
17. Should any leaks appear, repeat the above disassembly procedure and inspect for improper installation of seals. Repair or replace as required. Reassemble and repeat testing procedure.

For all other maintenance, it is recommended that the unit be sent back to Combustex for rebuilding and complete testing.

..... **NOTES**

The “Canalta,” “Combustex Burner Ignition & Control Systems” and “Pilot Pro” names and logos are trademarks of Canalta Controls Ltd. All other trademarks are the property of their respective owners.

Due to Canalta’s commitment to quality and innovation, all product designs, specifications and information materials, including the contents of this publication, are subject to change without notice. Responsibility for the proper selection, maintenance and use of any product remains with the customer. SAFETY FIRST.

© 2012 Canalta Controls Ltd. All rights reserved. Unauthorized reproduction in whole or in part is prohibited.



For operational, technical or installation assistance, please contact us.

Phone: 403.342.4494

Web: www.combustex.com

Call Us Toll Free: 1-855-226-2582